



BRUSSELSESTEENWEG, 416
B-9218 GENT
BELGIUM
TEL. : 00-32-91-31.21.11
TELEX : 12521 HAM B

© www.ham-international.eu

SOLID STATE LINEAR POWER AMPLIFIER

HAM INTERNATIONAL
LA-60/LA-120

© www.ham-international.eu

OPERATING MANUAL

Before attempting to use this RF power amplifier, read the following instructions thoroughly and familiarize yourself with details necessary for proper operation.

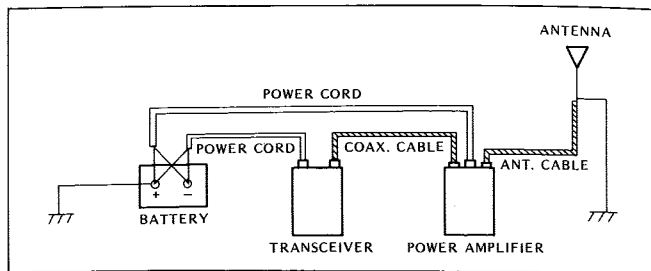

1. Features

● High performance RF transistors:

Selected latest RF power transistors with sufficient margin output used in this amplifier withstand severe working conditions, and largely improve the sound quality in communication which often has been a problem inherent in the transistorized RF power amplifier of this kind.

● Automatic send-receive switching:

The builtin, high sensitive carrier-control system makes the send-receive operation easy. The variable relay time-constant provides settings for stable transmitting conditions in the SSB mode operation.

● Selectable output level:

Three output levels in AM mode; 25 W, 50 W and 100 W, can be selected depending on receiving conditions at the station you are working with. In SSB mode, the output level of 120-200 W PEP is available with the input of

5-15 W PEP.

● Protection circuit for wrong power connection:

When the power source is connected to the amplifier unit carelessly with reverse polarity, the builtin protection circuit prevents voltage application to the internal circuit of the amplifier, and the fuse will blow to protect the costly power transistors.

● Harmonics suppression circuit.

The push-pull connection in the power amplifier minimizes unnecessary and harmful emission of higher and lower harmonics.

2. Operational instructions

* The power source voltage for this amplifier is rated to 13.8 Vdc as the standard. Do not use other voltages such as 6 Vdc or 24 Vdc which may break the aml amplifier.

* Verify the correct polarity before the amplifier is connected to the car battery or other sources. The supplied power cord consisting of a red wire (positive) and a black wire (negative) carries a relatively large current when the amplifier is in transmission. Avoid power cord splice for longer extension and cord connection to a car cigar lighter to prevent voltage drop in the power cord which leads to a reduced output below the rated value. Connect the power cord directly to terminal posts of car battery with as small length as possible.

* Reduce the drive input from a transceiver which exceeds 10 W in AM mode to the optimum value of 3-5 W before connecting to the amplifier because an excessive AM input may damage the power amplifier circuits.

* Carefully check and ascertain that the antenna system

including the coaxial cable contains no broken conductor and no shorted circuits inside before connecting to the amplifier. If the power amplifier is operated with an overlooked defect in its antenna system, the power transistor failure may result.

* A poor impedance matching between the antenna and the feeder (high SWR) will also damage the power transistor. It is recommended that the SWR is adjusted below 1.5 before operation.

* The power amplifier is subjected to perfect adjustment and severe shipping inspection before delivery eliminating the need for readjustment of the interior at the customer.

* The customer must not touch the components such as coils and trimpots inside the amplifier unit. Changes of component settings and modification by the customer may cause unusual performance and malfunction of the amplifier. The manufacturer is not liable at all to such defects that are attributable to the above causes.

* When this amplifier is used at a fixed station in a house, it is recommended that a low-pass filter and an antenna tuner are inserted between the antenna feeder and the power amplifier to re-reduce spurious emission which causes TV and radio interference.

3. Operations

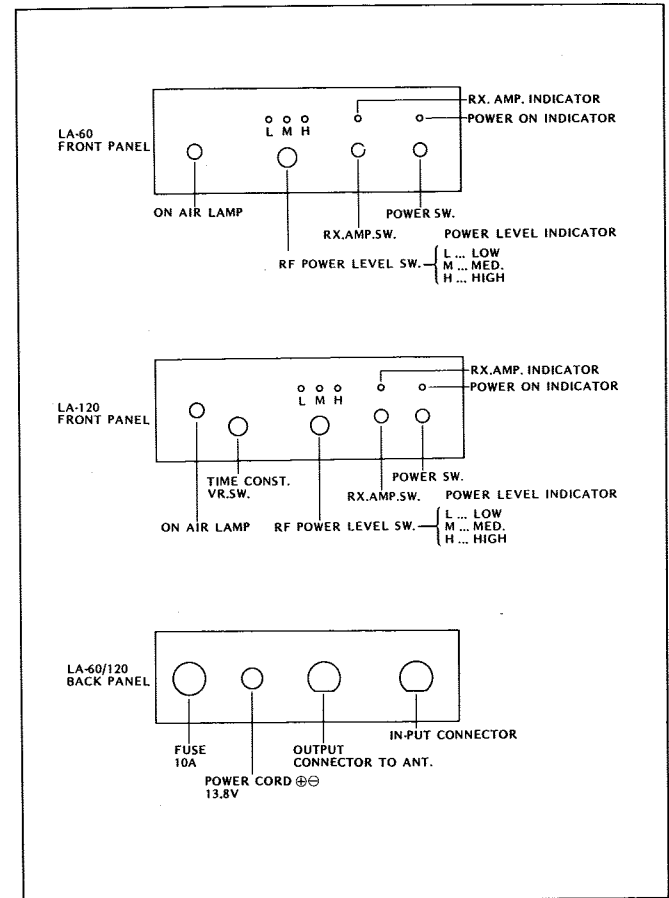

4. Specifications

• LA-60

Standard power source voltage	13.8Vdc, negative grounded
Working voltage range	11-14 Vdc
Frequency range	28 MHz
Applicable transmission mode	AM, SSB, FM, CW
Power output	AM; 50 W with 4 W input, 3 stages (50 W, 25 W, 10 W) are manually switched. SSB; 60-120 W PEP with 5-10 W PEP input
RF drive input	AM; 5 W max., SSB; 8 W max.
Maximum power current	6-5A at 50 W AM output
Carrier control drive input	1.0-1.5 W
Input/output impedance	50 ohms, unbalanced
Input/output joint	Type M connectors
Semiconductors used	5 transistors, 6 diodes,
Accessaries	Spare fuse 1 pc Screws and brackets 1 set Instruction manual 1 cpy
Dimensions	150X150X70 mm
Weight	1.6kg

• LA-120

Standard power source voltage	13.8Vdc, negative grounded
Working voltage range	11-14 Vdc
Frequency range	3.5-30 MHz
Applicable transmission mode	AM, SSB, FM, CW
Power output	AM; 100 W with 4 W input, 3 stages (100 W, 50 W, 25 W) are manually switched. SSB; 120-200 W PEP with 5-15 W PEP input
RF drive input	AM; 5 W max., SSB; 15 W max.
Maximum power current	15 A at 100 W AM output
Carrier control drive input	1.0-1.5 W
Input/output impedance	50 ohms, unbalanced
Input/output joint	Type M connectors
Semiconductors used	5 transistors, 8 diodes,
Accessaries	Spare fuse 1 pc Screws and brackets 1 set Instruction manual 1 cpy
Dimensions	150X200X70 mm
Weight	2.3kg